

HARDWARE FITTINGS

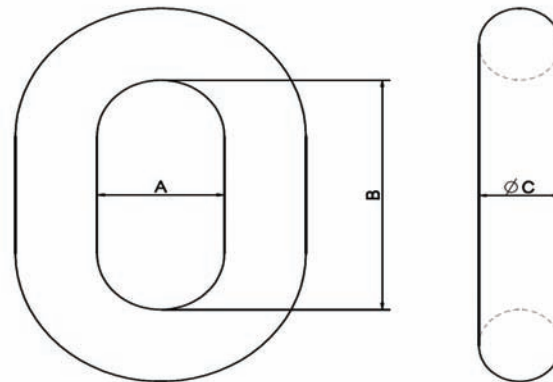

CHAIN LINK

Part Number	Drawing Number	Min. Breaking Strength (kN)	A (mm)	B (mm)	C (mm)
F41851-000	A4DD14166T	120	25	51	Ø16
846592-000	A4DD16406T	140	24	70	Ø18
D24127-000	A4DD14165T	160	30	64	Ø20
776520-000	A4DD1202T	260	32	76	Ø22
812514-000	A4DD06905T	454	51	102	Ø26

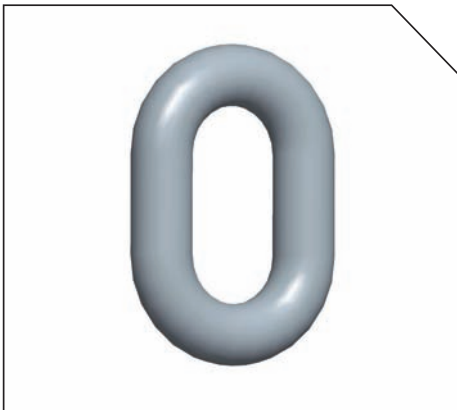

Material: Galvanized Forged Steel

TWISTED EYE TONGUE

Part Number	Drawing Number	Min. Breaking Strength (kN)	A (mm)	B (mm)	C (mm)	D (mm)	E (mm)	F (mm)
EA7221-000	A4DD16697T	70	51	110	26	Ø14	Ø18	16
C44757-000	A4DD15093T	120	51	110	26	Ø16	Ø18	16
141050-000	A4DD09801T	120	51	105	26	Ø18	Ø18	19
D00730-000	A4DD15131T	120	51	105	26	Ø18	Ø22	19

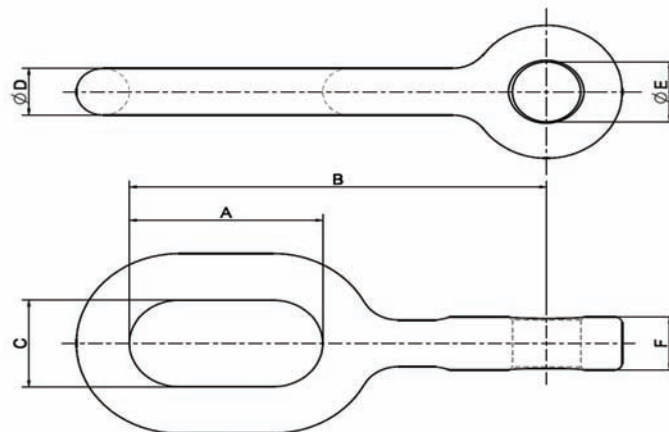
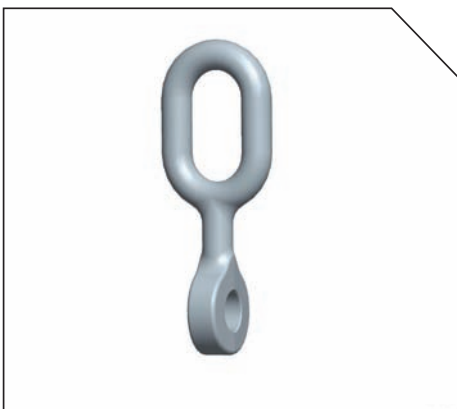

Material: Galvanized Forged Steel

HARDWARE FITTINGS

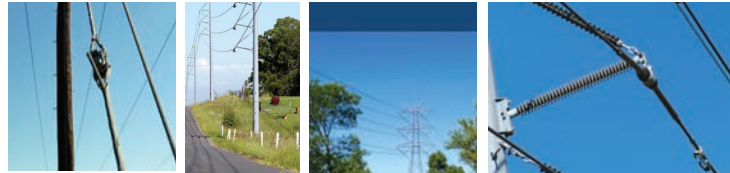

TWISTED EYE TONGUE (CONT.)

Part Number	Drawing Number	Min. Breaking Strength (kN)	A (mm)	B (mm)	C (mm)	D (mm)	E (mm)
C64059-000	A4DD14701T	120	60	47.5	16	Ø22	Ø18
CJ8273-000	A4DD16206T	120	60	47.5	16	Ø22	Ø22

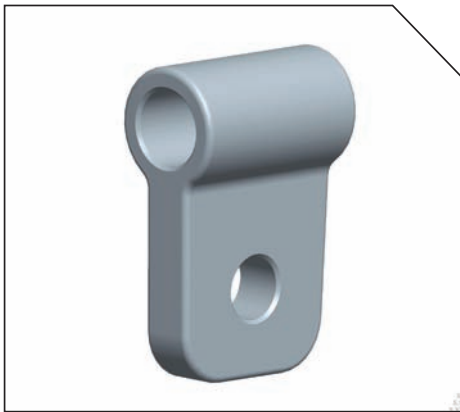

Material: Galvanized Forged Steel

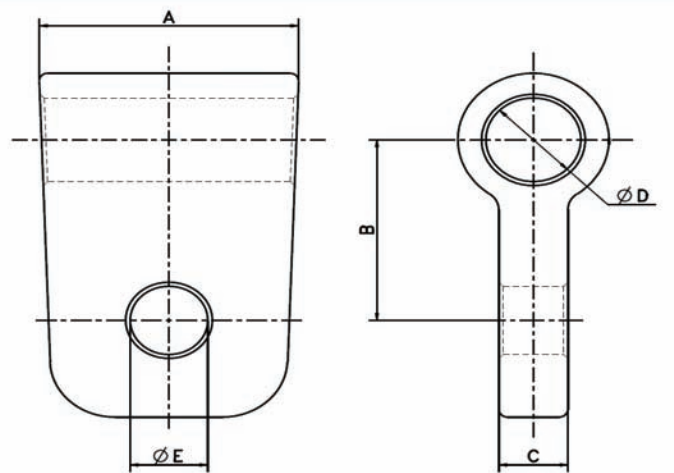

Part Number	Drawing Number	Min. Breaking Strength (kN)	A (mm)	B (mm)	C (mm)	D (mm)	E (mm)	F (mm)
P00230-000	A4DD16692T	70	51	370	25	Ø16	Ø18	16

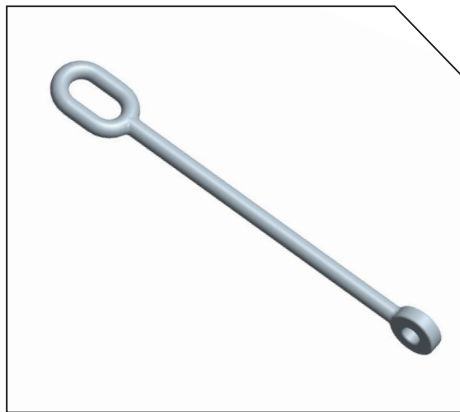

Material: Galvanized Forged Steel

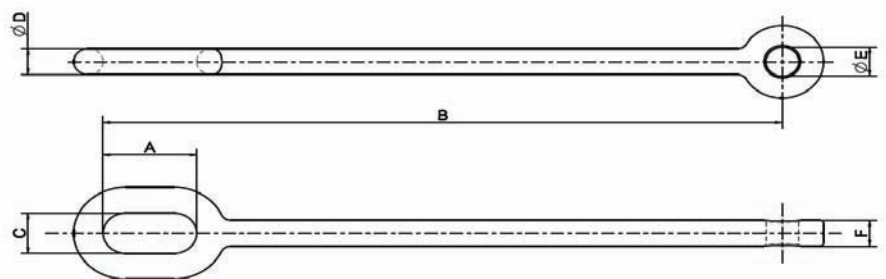

HARDWARE FITTINGS



TWISTED EYE TONGUE FOR ARCING HORN

Part Number	Drawing Number	Min. Breaking Strength (kN)	A (mm)	B (mm)	C (mm)	D (mm)	E (mm)	F (mm)
D23592-000	A4DD14008T	120	60	160	30	Ø16	16	Ø18

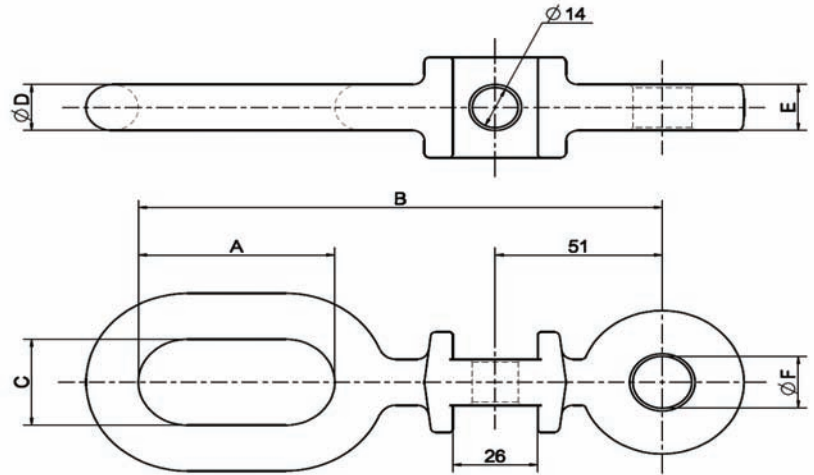

Material: Galvanized Forged Steel

OPEN THIMBLE

Part Number	Drawing Number	A (mm)	B (mm)	C (mm)
729000-000	A4DD17838T	32	17.5	14

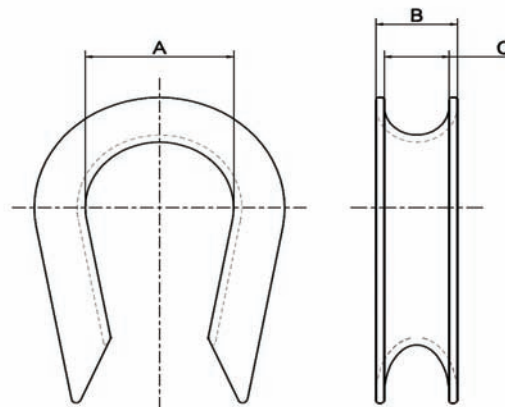
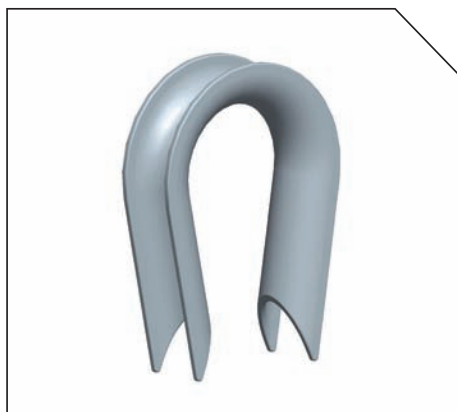

Material: Galvanized Steel

HARDWARE FITTINGS

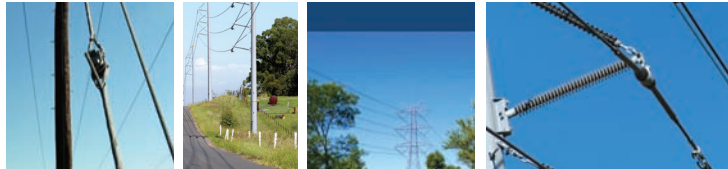

CIRCULAR CLOSED THIMBLE

Part Number	Drawing Number	A (mm)	B (mm)	C (mm)
C32295-000	A4DD08511T	25	17.5	20.5

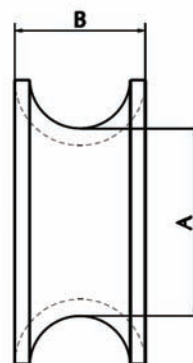
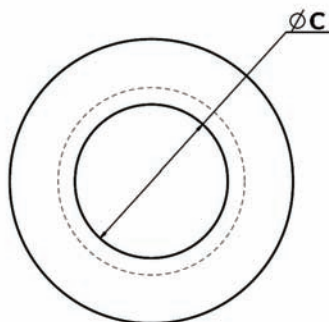

Material: Galvanized Steel

Part Number	Drawing Number	A (mm)	B (mm)	C (mm)
517194-000	DK89094	57	19	53

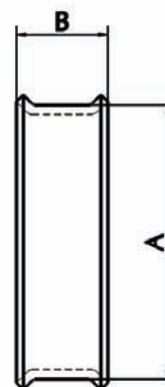
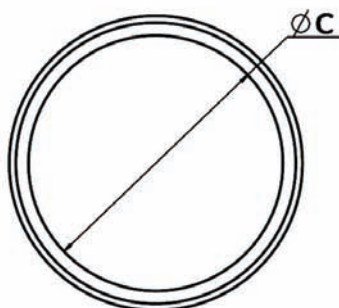
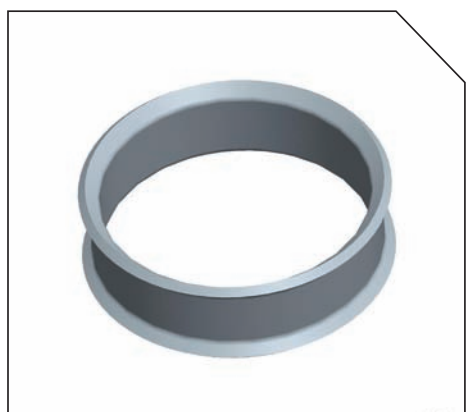

Material: Galvanized Steel

HARDWARE FITTINGS



TWISTED EYE/EYE EXTENSION LINK

Part Number	Drawing Number	Min. Breaking Strength (kN)	A (mm)	B (mm)	C (mm)	D (mm)
800610-000	A4DD17727T	90	70	874	35	Ø16
040672-000	A4DD17732T	120	70	330	35	Ø20

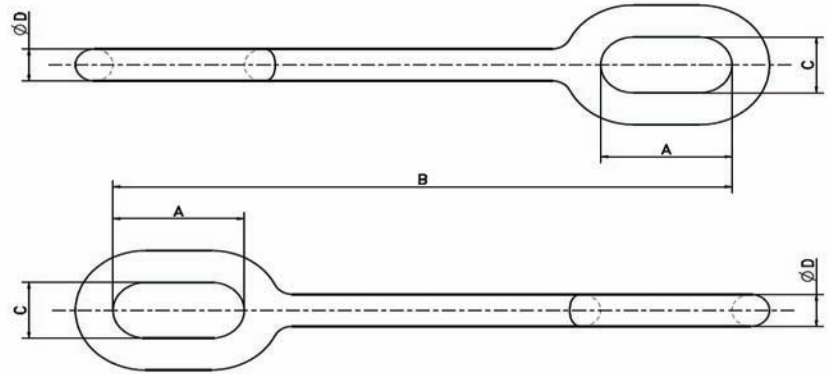
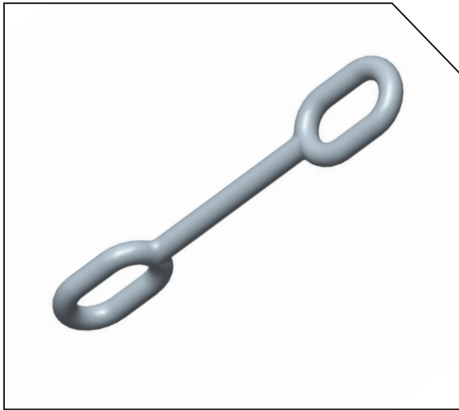

Material: Galvanized Forged Steel

TWISTED EYE/EYE EXTENSION LINK

Part Number	Drawing Number	Min. Breaking Strength (kN)	A (mm)	B (mm)	C (mm)	D (mm)
217074-000	A4DD07990T	162	76	330	38	Ø19
701776-000	A4DD07990T	162	76	654	38	Ø19
301334-000	A4DD07990T	162	76	983	38	Ø19
692526-000	A4DD07990T	162	76	1939	38	Ø19
E03190-000	A4DD07990T	162	76	2155	38	Ø19

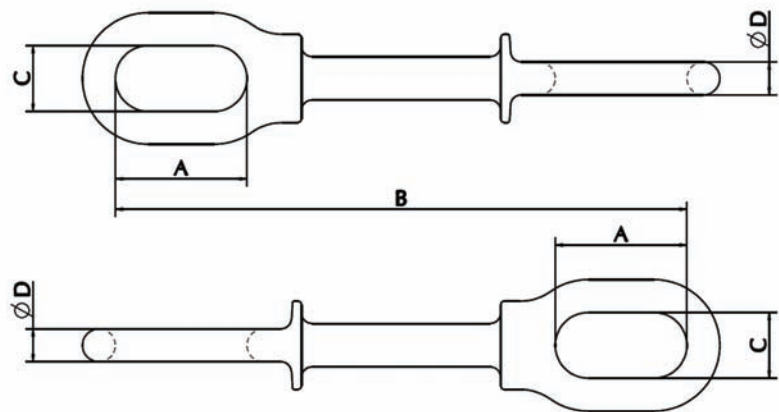
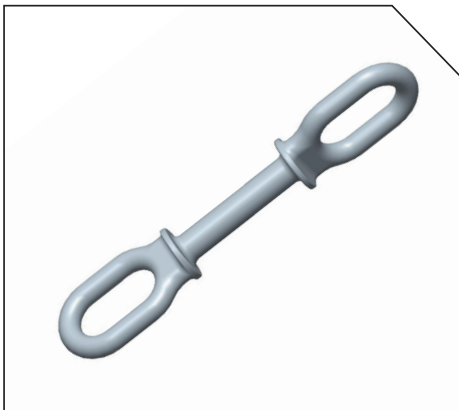

Material: Galvanized Forged Steel

HARDWARE FITTINGS



EYE/EYE EXTENSION LINK

Part Number	Drawing Number	Min. Breaking Strength (kN)	A (mm)	B (mm)	C (mm)	D (mm)
300304-000	A4DD07978T	445	100	356	38	Ø25

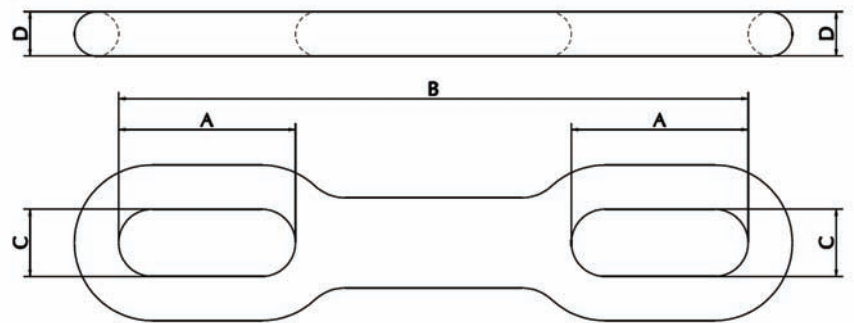
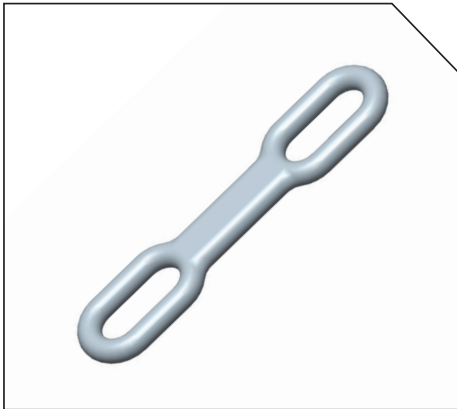

Material: Galvanized Forged Steel

Part Number	Drawing Number	Min. Breaking Strength (kN)	A (mm)	B (mm)	C (mm)	D (mm)
196228-000	A4DD17406T	103	70	401	35	Ø16
P00539-000	A4DD17532T	120	70	1920	35	Ø20

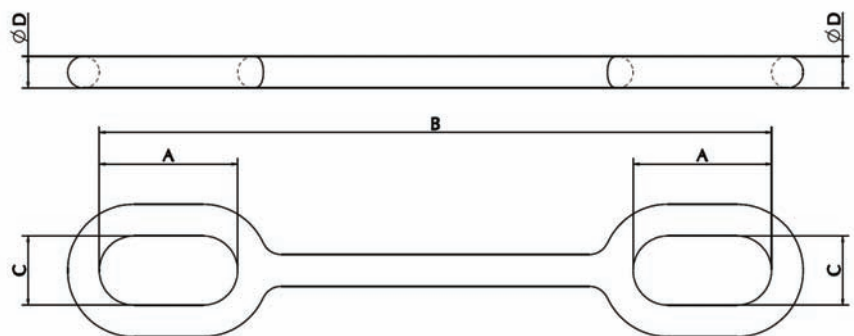
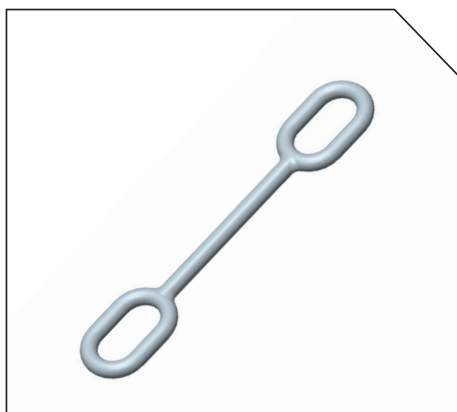

Note: Galvanized Forged Steel

HARDWARE FITTINGS



EYE/EYE EXTENSION LINK (CONT.)

Part Number	Drawing Number	Min. Breaking Strength (kN)	A (mm)	B (mm)	C (mm)	D (mm)	E (mm)
D47110-000	A4DD08926T	162	76	1527	38	Ø19	Ø25

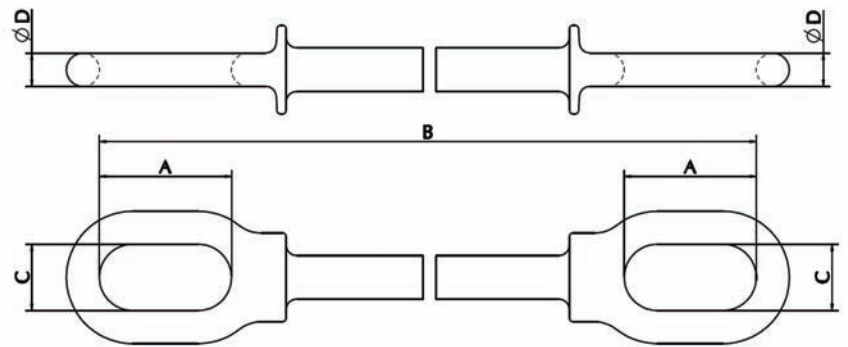
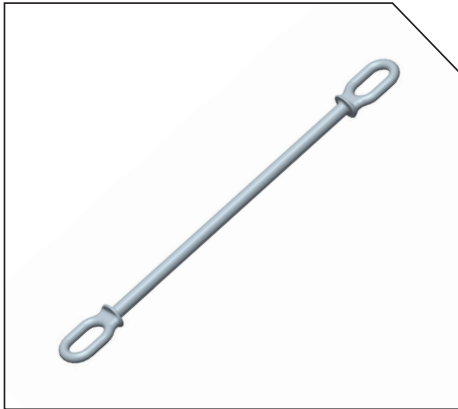

Material: Galvanized Forged Steel

Part Number	Drawing Number	Min. Breaking Strength (kN)	A (mm)	B (mm)	C (mm)	D (mm)	E (mm)
469388-000	A4DD07988T	323	80	559	38	Ø25	Ø45
285024-000	A4DD07988T	323	80	1700	38	Ø25	Ø45
E02714-000	A4DD14794T	445	80	965	38	Ø25	Ø45

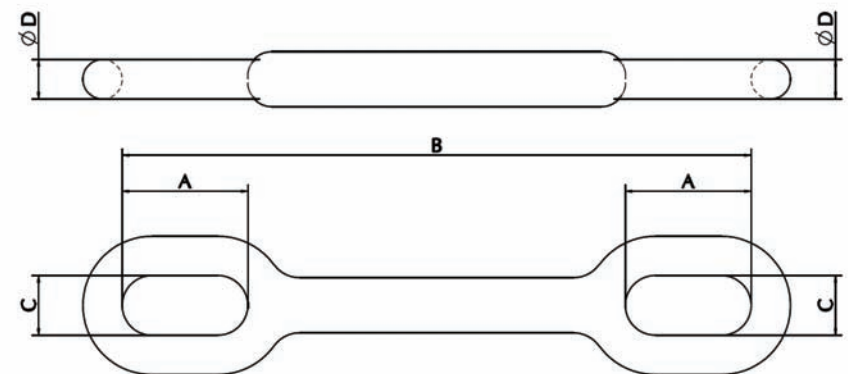
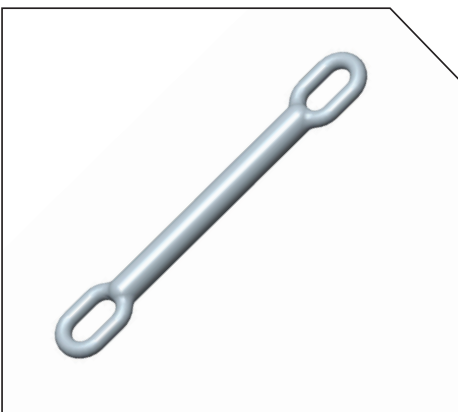

Material: Galvanized Forged Steel

HARDWARE FITTINGS



CLEVIS EYE EXTENSION LINK

Part Number	Drawing Number	Min. Breaking Strength (kN)	A (mm)	B (mm)	C (mm)	D (mm)	E (mm)	F (mm)
D06653-000	A4DD14465T	75	355	33	21	19	Ø18	Ø18

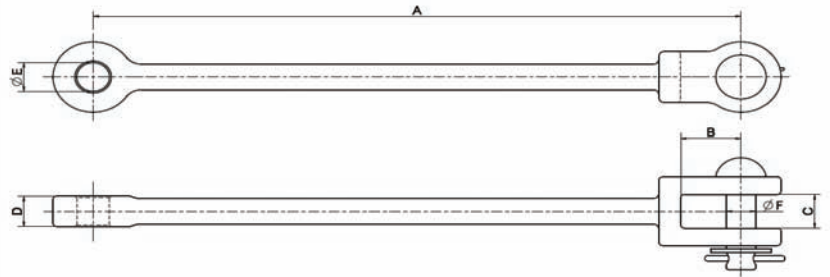
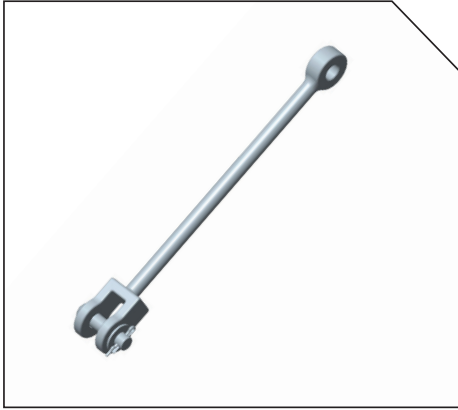

Material: Galvanized Ductile Iron

CLEVIS CLEVIS EXTENSION STRAP 18"

Part Number	Drawing Number	Min. Breaking Strength (kN)	A (mm)	B (mm)	C (mm)	D (mm)
666738-000	A4DD3188T	75	355	33	Ø18	Ø18

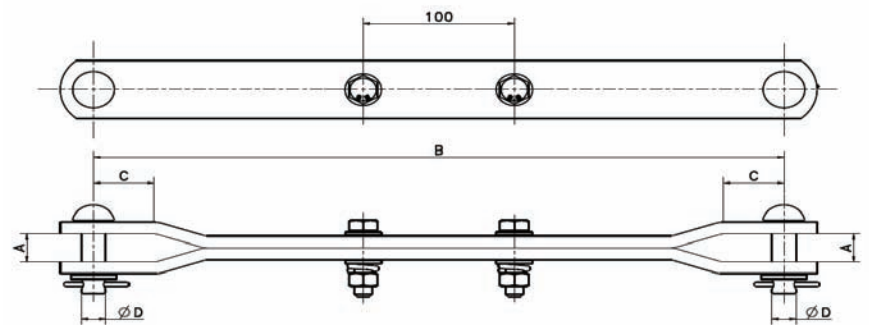
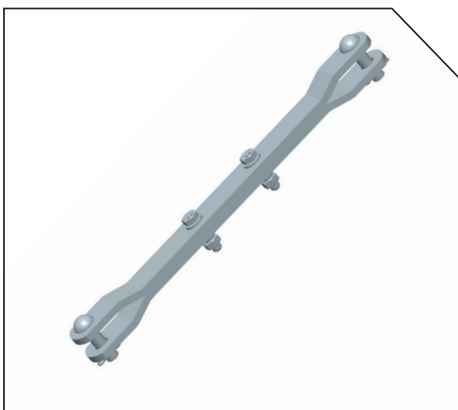

Material: Galvanized Steel

HARDWARE FITTINGS



EYE/CLEVIS TURNBUCKLES

Part Number	Drawing Number	Min. Breaking Strength (kN)	A (mm)	B (mm)	C (mm)	D (mm)	E (mm)	E (mm)	F (mm)
912190-000	A4DD17841T	120	155	430-573	53	46	25	25	Ø16
228406-000	A3DD06412T	125	242	500-740	53	46	25	25	Ø16
031484-000	A4DD16232T	120	305	550-790	53	46	25	25	Ø16
958324-000	A4DD17880T	120	305	560-840	50	45	25	27	Ø16
765624-000	A4DD16868T	125	242	500-740	53	46	25	25	Ø16
E12080-000	A3DD06573T	160	258	560-760	55	58	30	28	Ø20

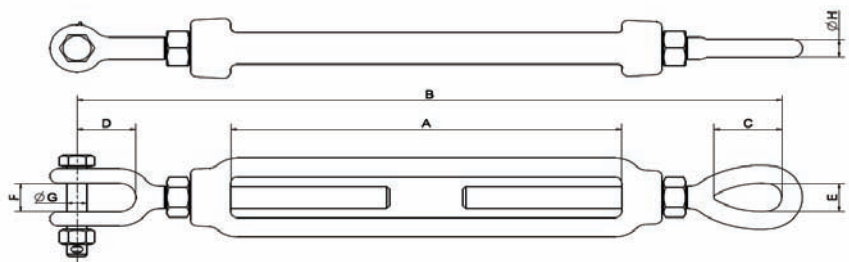
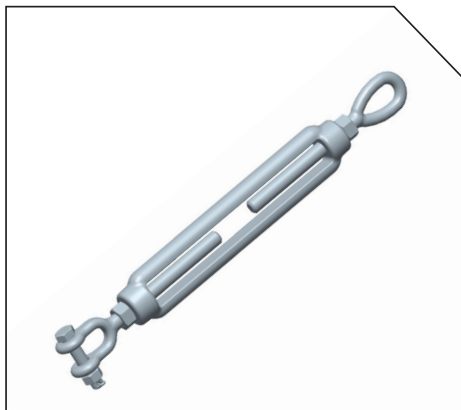

Material: Galvanized Forged Steel

EYE/EYE TURNBUCKLES

Part Number	Drawing Number	Min. Breaking Strength (kN)	A (mm)	B (mm)	C (mm)	D (mm)	E (mm)
P00268-000	A4DD17521T	120	305	572-853	50	25	Ø16
827050-000	A4DD10224T	125	242	500-740	53	25	Ø16
702574-000	A4DD17623T	160	155	480-605	55	30	Ø20
C88458-000	A3DD3731T	160	258	560-790	55	30	Ø20
476372-000	A4DD16233T	160	305	610-840	55	30	Ø20

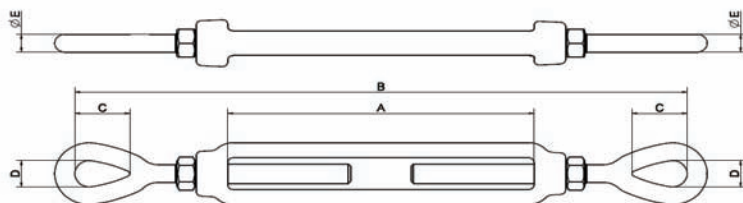
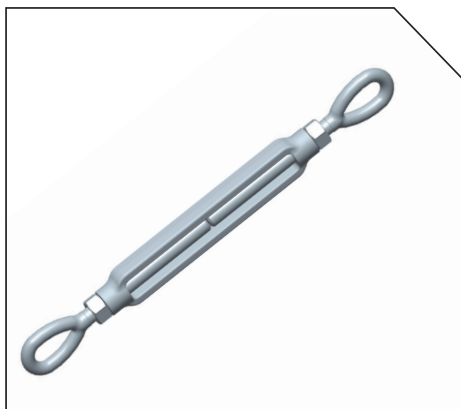

Material: Galvanized Forged Steel

HARDWARE FITTINGS



CLEVIS/CLEVIS TURNBUCKLES

Part Number	Drawing Number	Min. Breaking Strength (kN)	A (mm)	B (mm)	C (mm)	D (mm)	E (mm)
A10177-000	A4DD11971T	120	242	500-720	46	25	Ø16
937134-000	A3DD0429T	160	258	520-720	58	28	Ø20
230874-000	A4DD16231T	160	305	570-770	58	28	Ø20
P00278-000	A4DD17520T	120	305	548-830	45	27	Ø20

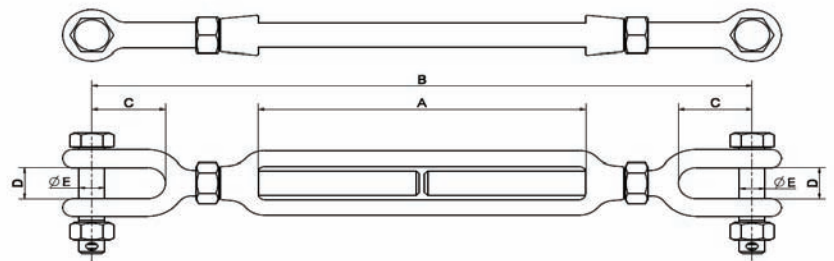
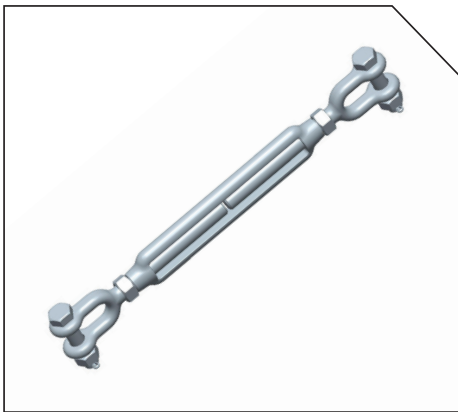

Material: Galvanized Forged Steel

